

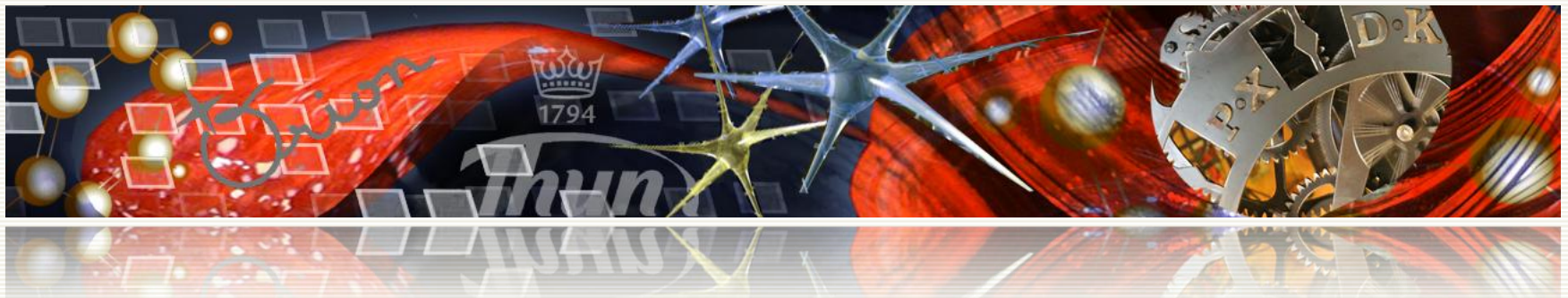

Nový **ESPACENET** beta verze

MZK Brno

ÚPV





Co je Espacenet?

- Volně přístupná databáze
- Informace o vynálezech a technických řešeních od 19. st. až do současnosti
- Více než 100 mil. patentových dokumentů (patentové přihlášky, patenty užité vzory....) z celého světa





Proč nový Espacenet (beta)?

- Každý (téměř) vyhledává na Internetu
- Každý má určitá očekávání (plný text, dynamická rešeršní maska)

Splňuje dosavadní Espacenet požadavky současných uživatelů?

Nové rysy:

- Více se podobá oblíbeným vyhledávačům
- Vhodný i pro méně zkušené uživatele
- Jasná prezentace výsledků
- Není nezbytné směřovat k vyšší „profesionální“ funkcionalitě



Výhody pro koncové uživatele

- Snadnější přístup
- Uživatelsky přívětivé vyhledávání
- Snadnější navigace
- Uzpůsobení pro mobilní zařízení (telefon, tablet)



Espacenet – beta verze od 19.11.2018

<http://www.epo.org>
<http://espacenet.com/beta>

Espacenet - patent search



Global Patent Index (GPI)

European Publication Server

Searching Asian documents

EP full-text search

Espacenet patent search

 Print  Share



With its worldwide coverage and simple search features, Espacenet offers free access to information about inventions and technical developments from 1836 to today.

Open Espacenet > National patent offices' databases

Try out new Espacenet (beta)

Support

Talk to EPO experts or get help from other users

> **Visit the discussion forum**

Contact

> **Contact us**

Common Citation Document (CCD)

> **Watch a short introductory video**

Espacenet is accessible to beginners and experts and is updated daily. It contains data on more than 100 million patent documents from around the world. Supporting information can help you understand whether a patent has been granted and if it is still in force.



Enter your search terms



Welcome to Espacenet: free access to over 100 million patent documents

magnetic particle imaging

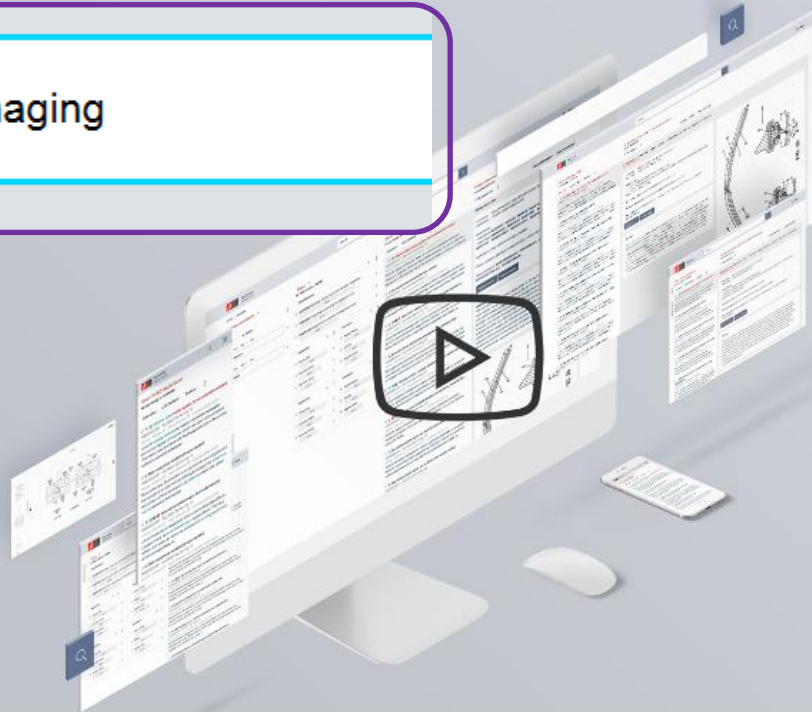

This is a beta version of Espacenet

[Your feedback](#)

[Why a beta version?](#)



Espacenet
Patent search

magnetic particle imaging

My Espacenet
 Help
 Classification search
 Results
 Advanced search
 Filters
 Tooltips

Home > Results

62502 results found, 178652 publications

List view List content Sort by
 Text only ▾ All ▾ Ranking ▾ ⋮

- 1. **MAGNETIC PARTICLE IMAGING**
 US2018017640A1 • GOODWILL PATRICK W [US]
Earliest priority: 2016-07-12 • Earliest publication: 2018-01-18
 A **Magnetic Particle Imaging (MPI)** system with a magnet configured to generate a **magnetic field** having a field free line, the system including at least one shim magnet configured to modify the **magnetic field** in a manner
- 2. **Steel pipe magnetic powder flow detection imaging detection...**
 CN107764894A • BAOSHAN IRON & STEEL
Earliest priority: 2016-08-22 • Earliest publication: 2018-03-06
 The invention relates to a steel pipe **magnetic powder flow detection imaging detection system** and a steel pipe **magnetic powder flow detection imaging detection method**. The steel pipe **magnetic powder flow detection**
- 3. **COIL DEVICE FOR MAGNETIC PARTICLE IMAGING AND...**
 JP2017086778A • MITSUBISHI ELECTRIC CORP
Earliest priority: 2015-11-17 • Earliest publication: 2017-05-25
 PROBLEM TO BE SOLVED: To provide a coil device for **magnetic particle imaging** which, without extremely enlarging the device, scans a zero **magnetic field region** in a subject in a direction perpendicular to a coil axis
- 4. **Particle Populations and Assays Having Varying Amounts o...**
 US2014021437A1 • BERNARD BRUCE JUNG



Query language: All ▾

AND ▾

+ Field

AND ▾ + Field x

Title ▾ All ▾ → Group

x

Title or abstract ▾ All ▾ → Group

x

OR ▾ + Field x

Publication number ▾ Any ▾ → Group

x

Application number ▾ Any ▾ → Group

x

Priority number ▾ Any ▾ → Group

x

Query language: All ▾

Publication date ▾ = ▾ → Group

x

OR ▾ + Field x

Applicants ▾ Any ▾ → Group

x

Inventors ▾ Any ▾ → Group

x

OR ▾ + Field x

CPC ▾ Any ▾ → Group

x

IPC ▾ Any ▾ → Group

x

Search

Reset



Patent search

magnetic particle imaging

Office/Language

My Espacenet Help Classification search Results Advanced search Filters Tooltips Feedback

Home > Results

Query language: All

Family Publication

62502 results found, 178652 publications

AND + Field

- All text fields or names Any → Group
 - magnetic x
- All text fields or names Any → Group
 - particle x
- All text fields or names Any → Group
 - imaging x

Search Reset

- Countries (publication)
- Languages (publication)
- Publication date (publication)
- Priority date
- IPC main groups
- IPC details
- CPC main groups
- CPC details
- Applicants
- Inventors

List view Text only List content All Sort by Ranking

- 1. **MAGNETIC PARTICLE IMAGING**
US2018017640A1 • GOODWILL PATRICK W [US]
Earliest priority: 2016-07-12 • Earliest publication: 2018-01-18
A **Magnetic Particle Imaging** (MPI) system with a magnet configured to generate a **magnetic** field having a field free line, the system including at least one shim magnet configured to modify the **magnetic** field in a manne...
- 2. **Steel pipe magnetic powder flaw detection imaging detecti...**
CN107764894A • BAOSHAN IRON & STEEL
Earliest priority: 2016-08-22 • Earliest publication: 2018-03-06
The invention relates to a steel pipe **magnetic** powder flaw detection **imaging** detection system and a steel pipe **magnetic** powder flaw detection **imaging** detection method. The steel pipe **magnetic** powder flaw detection...
- 3. **COIL DEVICE FOR MAGNETIC PARTICLE IMAGING AN...**
JP2017086778A • MITSUBISHI ELECTRIC CORP
Earliest priority: 2015-11-17 • Earliest publication: 2017-05-25
PROBLEM TO BE SOLVED: To provide a coil device for **magnetic particle** **imaging** which, without extremely enlarging the device, scans a zero **magnetic** field region in a subject in a direction perpendicular to a coil axis...
- 4. **Particle Populations and Assays Having Varying Amounts...**
US2011204874A1 • BERNARD BRUCE ILSI

Family Publication

IPC main groups

Countries (publication)

- US (85566)
- WO (29609)
- EP (14747)
- AU (12616)
- CA (12134)
- JP (8622)
- CN (4623)
- KR (12602)

Apply

Exclude

IPC details

- A61P35/00 (2341)
- A61K39/395 (1715)
- A61P43/00 (1635)
- C12N15/09 (1586)
- A61K45/00 (1384)
- G01N33/53 (1250)

Applicants

- AMGEN RES MUNICH GMBH (29)
- AGENSYS INC (27)
- AMGEN RES (MUNICH) GMBH (26)
- PFIZER (25)
- UNIV CALIFORNIA (25)
- ATYR PHARMA INC (22)
- GHAYUR TARIQ (22)
- GOLDENBERG DAVID M (22)

Apply

Exclude

Family Publication

Countries (publication)

Languages (publication)

Publication date (publication)

1971 From 2007 To 2018 2018

Apply

Priority date

Inventors



Espacenet
Patent search

magnetic particle imaging



My Espacenet

Help

Classification search

Results



Advanced search



Filters



Tooltips

Home > Results

Filters: Countries (publication): EP OR AU x Publication date (publication): 2007-01-01 — 2018-12-31 x IPC details: A61K39/395 x Applicants: PFIZER x

Family Publication

30 results found, 65 publications

List view

List content

Sort by

Text only

All

Ranking



Countries (publication)

Languages (publication)

Publication date (publication)

Priority date

IPC main groups

IPC details

CPC main groups

CPC details

Applicants

Inventors

- 1. **Cancer cell targeting using nanoparticles**
EP2436376A1 • BIND BIOSCIENCES INC [US]
Earliest priority: 2007-03-30 • Earliest publication: 2008-10-09
The present invention generally relates to polymers and macromolecules, in particular, to polymers useful in particles such as nanoparticles. One aspect of the invention is directed to a method of developing
- 2. **Therapeutic nanoparticles comprising a therapeutic agent...**
AU2017218767A1 • PFIZER
Earliest priority: 2016-02-10 • Earliest publication: 2017-08-17
The present disclosure generally relates to nanoparticles comprising an antibody, such as an anti-PD-1 antibody. Other aspects include methods of making and using such nanoparticles. In an embodiment, the
- 3. **Anti-CXCR4 antibodies and antibody-drug conjugates**
AU2014298040A1 • PFIZER
Earliest priority: 2013-08-02 • Earliest publication: 2015-02-05
The present invention provides antibodies and related molecules that bind to chemokine receptor 4 (CXCR4). The invention further provides



Home > Results > EP2436376A1

Filters: Countries (publication): EP OR AU X Publication date (publication): 2007-01-01 — 2018-12-31 X IPC details: A61K39/395 X Applicants: PFIZER X

30 results found, 65 publications

List view Text only List content All Sort by Ranking

- 1. Cancer cell targeting using nanoparticles EP2436376A1 • BIND BIOSCIENCES INC [US] Earliest priority: 2007-03-30 • Earliest publication: 2008-10-09 The present invention generally relates to polymers and macromolecules, in particular, to polymers useful in particles such as nanoparticles. One aspect of the invention is directed to a method of developing nanoparticles...
- 2. Therapeutic nanoparticles comprising a therapeutic agent a... AU2017218767A1 • PFIZER Earliest priority: 2016-02-10 • Earliest publication: 2017-08-17 The present disclosure generally relates to nanoparticles comprising an antibody, such as an anti-PD-1 antibody. Other aspects include methods of making and using such nanoparticles. In an embodiment, the nanoparticle...
- 3. Anti-CXCR4 antibodies and antibody-drug conjugates AU2014298040A1 • PFIZER Earliest priority: 2013-08-02 • Earliest publication: 2015-02-05 The present invention provides antibodies and related molecules that bind to chemokine receptor 4 (CXCR4). The invention further provides antibody-drug conjugates comprising such antibodies, antibody encoding...
- 4. PD-1 / PD-L1 inhibitors for the treatment of cancer AU2016222928A1 • MERCK PATENT GMBH

EP2436376A1 Cancer cell targeting using nanoparticles

Bibliographic data

Register

Inventors: ALI MIR MUKKARAM [US], ZALE STEPHEN E [US] Applicants: BIND BIOSCIENCES INC [US]

Classification: IPC: A61K31/337; A61K9/14; A61K9/48; A61K9/51; A61P35/00; B82B1/00

CPC: default: A61K31/136; A61K31/197; A61K31/337; A61K31/704; A61K47/542; A61K47/6935; A61K47/6937; A61K9/5153; A61K9/5192; B82Y5/00; G07C275/16; G07C275/24

Application number: EP11186037A Global Dossier

Priority numbers: US2007007927 20070330

Publication date: 2012-01-04

Also published as Patent Translate

Previous Next

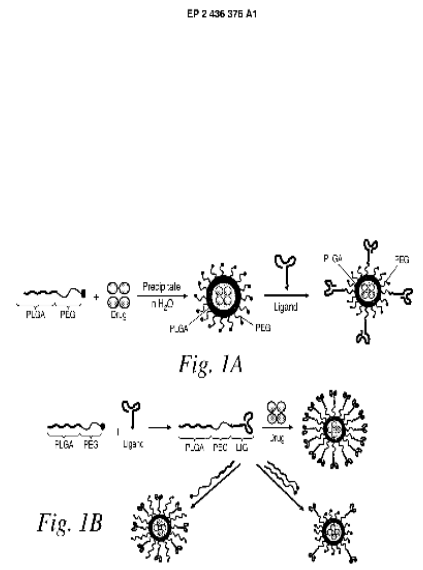



Query language: All

AND + Field

- All text fields or names Any → Group
 - 5G
- All text fields or names Any → Group
 - technology

Search Reset

AND + Field

- All text fields or names Any → Group
 - 5G
 - All
 - Text fields
 - Names
 - Dates
 - Numbers
 - Classification
 - Other
- All text fields or names Any → Group
 - technology
 - Title
 - Abstract
 - Description
 - Claims
 - Title or abstract
 - Title, abstract or claims
 - All text fields

Search

83002 results found, 135866 publications

List view: Text only | List content: All | Sort by: Ranking

- 1.METHOD AND APPARATUS FOR IMPLEMENTING A SERVICE FL...**
WO2016188701A1 • NOKIA SOLUTIONS & NETWORKS OY [FI]
Earliest priority: 2015-05-26 • Earliest publication: 2016-12-01
that the network node supports interworking between a first radio-access **technology** and a second radio- access **technology**. The method
- 2.METHOD AND APPARATUS FOR IMPLEMENTING INTER-RADIO-...**
WO2016118117A1 • CHANDRAMOULI DEVAKI [US]
Earliest priority: 2015-01-20 • Earliest publication: 2016-07-28
..... -access-**technology** for a service. The method may also include entering a coverage area of the at least one preferred radio-access-**technology**. The method may also include detecting that the service corresponding to the at least one preferred radio-access-
- 3.RADIO FRAME TRANSMISSION METHOD, BASE STATION AND U...**
WO2017101046A1 • HUAWEI TECH CO LTD [CN]
Earliest priority: 2015-12-16 • Earliest publication: 2017-06-22
Disclosed is a radio frame transmission method, comprising: sending, to a user equipment, a fifth generation (5G) downlink subframe, which bears first data, of the 5G radio access **technology** (RAT); and receiving an LTE uplink subframe of long term evolution... of the
- 4.BASE STATION, DATA TRANSMISSION METHOD AND APPARATUS**
WO2017219205A1 • BEIJING XIAOMI MOBILE SOFTWARE CO LTD [CN]
Earliest priority: 2016-06-20 • Earliest publication: 2016-11-16
..... mobile communication. The base station is deployed in a radio access network constructed according to a first mobile communication **technology**... the first mobile communication **technology** standard, and the user plane entity sends the user plane data

Query language: All ▾

AND ▾ + Field

Title ▾ Any ▾ → Group

5G x

All text fields or names ▾ Any ▾ → Group

technology x

Search Reset

389 results found, 478 publications

List view Text only ▾ List content All ▾ Sort by Ranking ▾ ⋮

- 1. 5G network communication device**
CN108173562A • SHENYANG INST ENGINEERING
Earliest priority: 2017-12-19 • Earliest publication: 2018-06-15
..... dense and ultra-dense networking **technology** block; wherein the lower ring body and an upper ring body are both semi... of the keys for communication nodes to achieve two-way communication, and is also the key **technology** for high throughput and low latency
- 2. 5G Network System**
KR20170052446A • ELECTRONICS & TELECOMMUNICATIONS RES I...
Earliest priority: 2015-11-03 • Earliest publication: 2017-05-12
The present invention relates to a 5G network system capable of effectively providing a communication service through a high-level architecture that integrates a 4G wireless network, a wired network, a cloud and a service evolved in various fields.
- 3. 5G network architecture based on edge calculates and microtomy**
CN207234831U • TIANYUAN RUIXIN COMMUNICATION TECH CO LTD
Earliest priority: 2017-09-18 • Earliest publication: 2018-04-13
The utility model relates to a 5G network architecture based on edge calculates and microtomy, includes data transmission framework and control mechanism, the data transmission framework calculates the layer including edge access layer, local stratum
- 4. 5G tunable antenna**
CN107887711A • XUNCHUANG TIANJIN ELECTRONIC CO LTD
Earliest priority: 2017-09-20 • Earliest publication: 2018-04-06
invention adopted, the connection of a mobile terminal and a base station is realized through the multi-antenna **technology**; a
- 5. 5G/LTE DUAL CONNECTIVITY**



Query language: All

AND

Title Any

5G x

All text fields or names Any

technology x

OR x

All text fields or names Any

multiple input multiple output x

All text fields or names Any

MIMO x

321 results found, 400 publications

List view: Text only | List content: All | Sort by: Ranking

- 1. CHANNEL STATE INFORMATION FRAMEWORK DESIGN FOR 5G...
US2018091272A1 • AT & T IP | LP [US]
Earliest priority: 2016-09-29 • Earliest publication: 2018-03-29
A user equipment can be configured to decompose a multiple input multiple output (MIMO) channel into multiple domains, measure the
- 2. Large-scale antenna system based on 5G network
CN106374983A • SICHUAN TIANYI COMHEART TELECOM CO LTD
Earliest priority: 2016-08-26 • Earliest publication: 2017-02-01
The invention discloses a large-scale antenna system based on a 5G network. The large-scale antenna system comprises multiple communication transceiving channels, multiple directional couplers, a calibration network, a fiber communication network, multiple micro
- 3. 5G network communication device
CN108173562A • SHENYANG INST ENGINEERING
Earliest priority: 2017-12-19 • Earliest publication: 2018-06-15
..... dense and ultra-dense networking technology block; wherein the lower ring body and an upper ring body are both semi... of the keys for communication nodes to achieve two-way communication, and is also the key technology for high throughput and low latency
- 4. Copper-Assisted Fifth Generation (5G) Wireless Access to Indoor
US2016294441A1 • FUTUREWEI TECHNOLOGIES INC [US]
Earliest priority: 2015-03-30 • Earliest publication: 2016-10-06
A network element including a relay station disposed outside a structure, wherein the relay station is configured to convert a radio frequency signal received from a base station into baseband signals and to frame the baseband signals into data packets, and a
- 5. Multiple dimension modulation in 5G systems



321 results found, 400 publications

List view Text only List content All Sort by Ranking

1. CHANNEL STATE INFORMATION FRAMEWORK DESIGN FOR 5G...
 US2018091272A1 • AT & T IP LLP [US]
 Earliest priority: 2016-09-29 • Earliest publication: 2018-03-29
 A user equipment can be configured to decompose a multiple input multiple output (MIMO) channel into multiple domains, measure the

2. Large-scale antenna system based on 5G network
 CN106374983A • SICHUAN TIANYI COMHEART TELECOM CO LTD
 Earliest priority: 2016-08-26 • Earliest publication: 2017-02-01
 The invention discloses a large-scale antenna system based on a 5G network. The large-scale antenna system comprises multiple communication transceiving channels, multiple directional couplers, a calibration network, a fiber communication network, multiple micro-

3. 5G network communication device
 CN108173562A • SHENYANG INST ENGINEERING
 Earliest priority: 2017-12-19 • Earliest publication: 2018-06-15
 dense and ultra-dense networking technology block; wherein the lower ring body and an upper ring body are both semi... of the keys for communication nodes to achieve two-way communication, and is also the key technology for high throughput and low latency

4. Copper-Assisted Fifth Generation (5G) Wireless Access to Indoor
 US2016294441A1 • FUTUREWEI TECHNOLOGIES INC [US]
 Earliest priority: 2015-03-30 • Earliest publication: 2016-10-06
 A network element including a relay station disposed outside a structure, wherein the relay station is configured to convert a radio frequency signal received from a base station into baseband signals and to frame the baseband signals into data packets, and a

5. Multiple dimension modulation in 5G systems

☆ US2018091272A1 CHANNEL STATE INFORMATION FRAMEWORK DESIGN FOR 5G MULTIPLE INPUT MULTIPLE OUTPUT TRANSMISSIONS

Also published as Patent Translate

Bibliographic data Description Claims Drawings Original document Citations Legal status Patent family

Inventors: GHOSH ARUNABHA [US], WANG XIAOYI [US]
Applicants: AT & T IP LLP [US]

Classification:
IPC: H04B7/0417; H04B7/06; H04L5/00

CPC: default: H04B7/0417; H04B7/0645; H04B7/0626; H04L5/0048

Application number: US201615376377A Global Dossier

Priority numbers: US201662401858 20160929

Publication date: 2018-03-29

Filing date: 2016-12-12

Priority date: 2016-09-29

Published as: US2018091272A1; WO2018063894A1

Abstract:

A user equipment can be configured to decompose a multiple input multiple output (MIMO) channel into multiple domains, measure the channel state

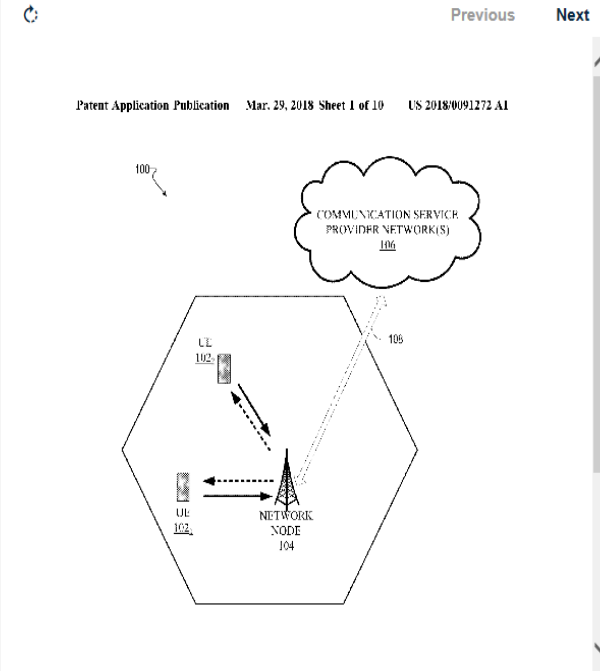



Espacenet Patent search

Office/Language ▾

My Espacenet
Help
Classification search
Results
Feedback

Classification search

Search for

View section
Index
A | B | C | D | E | F | G | H | Y |

« H04B5/00 H04B10/00 »

Classification symbol	Title and description	
<input type="checkbox"/> H	ELECTRICITY	<input type="button" value="S"/> <input type="button" value="🔍"/>
<input type="checkbox"/> H04	ELECTRIC COMMUNICATION TECHNIQUE	<input type="button" value="🔍"/>
<input type="checkbox"/> H04B	TRANSMISSION (transmission systems for measured values, control or similar signals G08C ; coding, decoding, code conversion, in general H03M ; broadcast communication H04H ; multiplex systems H04J ; secret communication H04K ; transmission of digital information H04L)	<input type="button" value="S"/> <input type="button" value="D"/> <input type="button" value="🔍"/> <input type="button" value="▲"/>
▲ <input type="checkbox"/> H04B 7/00	Radio transmission systems, i.e. using radiation field (H04B 10/00 , H04B 15/00 take precedence)	<input type="button" value="D"/>
<input type="checkbox"/> H04B 7/02	• Diversity systems; Multi-antenna system, i.e. transmission or reception using multiple antennas (RAKE receivers H04B 1/7115)	<input type="button" value="D"/> <input type="button" value="▲"/>
<input type="checkbox"/> H04B 7/04	•• using two or more spaced independent antennas	<input type="button" value="D"/>
<input checked="" type="checkbox"/> H04B 7/0413	••• MIMO systems	<input type="button" value="D"/> <input type="button" value="▲"/>
<input checked="" type="checkbox"/> H04B 7/0417	•••• Feedback systems	<input type="button" value="D"/>
<input checked="" type="checkbox"/> H04B 7/0421	••••• {utilizing implicit feedback, e.g. steered pilot signals}	<input type="button" value="D"/>

Selected classifications

H04B7/0413 /low ×

Clear



Patent search

cpc = "H04B7/0413/low" AND ti = "5G" [x] [Search icon]

My Espacenet Help Classification search Results Advanced search Filters Tooltips

Home > Results

Query language: All [v]

AND [v] + Field
CPC [v] = [v] → Group
H04B7/0413/low x
Title [v] = [v] → Group
5G x

Search [button] Reset [button]

18 results found, 27 publications

List view: Text only [v] List content: All [v] Sort by: Ranking [v] [More options icon]

- 1. BEAMFORMING COMMON CHANNELS IN 5G NEW RADIO WO2017136732A1 • DOCOMO INNOVATIONS INC [US]
2. DISTRIBUTED FD-MIMO: CELLULAR EVOLUTION FOR 5G... WO2018169357A1 • SAMSUNG ELECTRONICS CO LTD [KR]
3. LOW COMPLEXITY MU-MIMO PAIRING AND SCHEDULI... EP3379884A1 • MITSUBISHI ELECTRIC CORP [JP]
4. SECURED HYBRID CODED MODULATION FOR 5G - AN... US2018269972A1 • NEC LAB AMERICA INC [US]



My Espacenet

Help

Classification search

Results



Advanced search



Filters



Tooltips

Home > Results

Query language: All

AND + Field

Title or abstract Any Group

printer*

x

OR + Field x

Title or abstract Any Group

3D

x

Title or abstract All Group

three dimensional

x

Search

Reset

12686 results found, 15300 publications

List view

List content

Sort by

Text only

All

Ranking



1. THREE-DIMENSIONAL PRINTER

WO2018194652A1 • HEWLETT PACKARD DEVELOPMENT C...
Earliest priority: 2017-04-21 • Earliest publication: 2018-10-25

A three-dimensional (3D) printer includes a selective solidification module to selectively solidify portions of successive layers of a build material on a build platform. The 3D printer also includes a cartridge receiver to hold a

2. 3D (three -dimensional) printer

CN206598539U • JIANGXI INSTITUTE OF FASHION TECH
Earliest priority: 2017-01-23 • Earliest publication: 2017-10-31

The utility model relates to a printer technical field, concretely relates to 3D (three -dimensional) printer, include: the 3D (three... that 3D product that the 3D (three -dimensional) printer body was printed out exposes outside or in

3. 3D (three -dimensional) printer

CN205075343U • GUANGZHOU CHUANGJIA BUILDING MOD...
Earliest priority: 2015-08-19 • Earliest publication: 2016-03-09

The utility model discloses a 3D (three -dimensional) printer, include that 3D beats printer head, still include hollow rack, be... (three -dimensional) printer to can realize the remote control to 3D (three -dimensional) printer,

4. 3D (three -dimensional) printer

CN206484904U • BEIJING DIJIA MEDICAL EQUIPMENT CO L...
Earliest priority: 2017-02-23 • Earliest publication: 2017-09-12



Query language: All

AND

+ Field

Title or abstract Any

→ Group

printer*

x

OR

+ Field

x

Title or abstract Any

→ Group

3D

x

Title or abstract All

→ Group

three dimensional

x

Publication date >=

→ Group

2017

x

Search

Reset

6260 results found, 7158 publications

List view

List content

Sort by

Text only

All

Ranking

1. THREE-DIMENSIONAL PRINTER

WO2018194652A1 • HEWLETT PACKARD DEVELOPMENT C...

Earliest priority: 2017-04-21 • Earliest publication: 2018-10-25

A three-dimensional (3D) printer includes a selective solidification module to selectively solidify portions of successive layers of a build material on a build platform. The 3D printer also includes a cartridge receiver to hold a

2. 3D (three -dimensional) printer

CN206598539U • JIANGXI INSTITUTE OF FASHION TECH

Earliest priority: 2017-01-23 • Earliest publication: 2017-10-31

The utility model relates to a printer technical field, concretely relates to 3D (three -dimensional) printer, include: the 3D (three... that 3D product that the 3D (three -dimensional) printer body was printed out exposes outside or in

3. 3D (three -dimensional) printer

CN206484904U • BEIJING DIJIA MEDICAL EQUIPMENT CO L...

Earliest priority: 2017-02-23 • Earliest publication: 2017-09-12

The embodiment of the utility model provides a 3D (three -dimensional) printer, include: printer main part and agitating unit, agitating unit install in in the printer main part, just agitating unit's agitator stretches into holding in

4. THREE-DIMENSIONAL (3D) PRINTER MODULES

WO2018194624A1 • HEWLETT PACKARD DEVELOPMENT C...

Earliest priority: 2017-04-20 • Earliest publication: 2018-10-25



Home > Results

Family Publication

Countries (publication)



- US (658)
- WO (444)
- JP (182)
- EP (129)
- TW (66)
- RU (24)
- CA (21)
- All (20)

Apply

Exclude

Languages (publication)



6260 results found, 7158 publications

List view

List content

Sort by

Text only



All



Ranking



The present invention relates to a **three dimensional printer** for melting and discharging a raw filament to form a **three-dimensional shape** and, more specifically, to a **three dimensional printer**, comprising: a driving unit havin

78. **3D (three -dimensional) printer**

CN207657188U • SHENZHEN BKL TECH CO LTD

Earliest priority: 2017-09-14 • Earliest publication: 2018-07-27

The utility model relates to a **3D (three -dimensional) printer**, the base, be fixed in the vertical drive device of

79. **THREE DIMENSIONAL PRINTER APPARATUS**

WO2018132157A2 • ESSENTIUM MAT LLC [US]

Earliest priority: 2016-11-03 • Earliest publication: 2018-07-19

A **three-dimensional** printing apparatus for manufacturing a **three-dimensional** object includes a controller comprising a signal generator and a **three-dimensional printer**. The **three-dimensional printer** includes a print

80. **3D (three -dimensional) printer**

CN206690550U • ZHEJIANG FURUI 3D TECH CO LTD

Earliest priority: 2017-04-25 • Earliest publication: 2017-12-01

The utility model discloses a **3D (three -dimensional) printer**, including X axle subassembly, two Y axle subassemblies, two Z axle



My Espacenet Help Classification search Results Advanced search Filters Tooltips

Home > Results

Filters: Countries (publication):

Family Publication

- Countries (publication) ▾
- Languages (publication) ▾
- Publication date (publication) ▾
- Priority date ▾
- IPC main groups ▾
- IPC details ▾
- CPC main groups ▾
- CPC details ▾

Applicants

↑ ↓	↑ ↓	↑ ↓
<input checked="" type="checkbox"/>	HEWLETT PACKARD DEVELOPMENT CO	(38)
<input checked="" type="checkbox"/>	HEWLETT-PACKARD DEV COMPANY L P	(33)
<input checked="" type="checkbox"/>	XEROX CORP	(30)
<input type="checkbox"/>	KINPO ELECT INC	(26)
<input type="checkbox"/>	XYZPRINTING INC	(26)
<input type="checkbox"/>	BOSCH GMBH ROBERT	(14)
<input type="checkbox"/>	PRINT RITE UNICORN IMAGE PRODUCTS CO LTD ZHUHAI	(11)
<input type="checkbox"/>	PRINT RITE UNICORN IMAGE PRODUCTS CO LTD OF ZHUHAI	(11)

Apply Exclude

Inventors ▾

687 results found, 755 publications

List view Text only List content All Sort by Ranking

- 1. **THREE-DIMENSIONAL PRINTER**
WO2018194652A1 • HEWLETT PACKARD DEVELOPMENT CO [US]
Earliest priority: 2017-04-21 • Earliest publication: 2018-10-25
A **three-dimensional (3D) printer** includes a selective solidification module to selectively solidify portions of successive layers of a build material on a build platform. The **3D printer** also includes a cartridge receiver to hold a removable material cartridge that accepts material from the **3D printer** and makes material available to the **3D printer** for printing of the **3D**
- 2. **THREE-DIMENSIONAL (3D) PRINTER MODULES**
WO2018194624A1 • HEWLETT PACKARD DEVELOPMENT CO [US]
Earliest priority: 2017-04-20 • Earliest publication: 2018-10-25
In some examples, a service module of a **three-dimensional (3D) printer** can include a housing, a web to clean a print head of the **3D printer**, where the web is housed by the housing, and where the service module is removably attached to the **3D printer**, and a shield to shield the web. ...
- 3. **THREE-DIMENSIONAL PRINTING AND THREE-DIMENSIONAL PRINTERS**
WO2018005439A1 • VELO3D INC [US]
Earliest priority: 2016-06-29 • Earliest publication: 2018-01-03
The present disclosure provides **three-dimensional (3D)** printing processes, apparatuses, software, and systems for the production of at least one desired **3D** object. The **3D printer** system (e.g., comprising a processing chamber, build module, or an unpacking station) described herein may retain a desired (e.g., inert) atmosphere around the material bed and/or
- 4. **THREE-DIMENSIONAL (3D) PRINTING**
WO2017188967A1 • HEWLETT-PACKARD DEV COMPANY L P [US]
Earliest priority: 2016-04-29 • Earliest publication: 2017-11-02
In an example implementation, a method of operating a **three-dimensional (3D)** printing system includes forming a fused **3D** object in the printing tray of a **3D printer** and vibrating the tray to separate unfused material from the fused **3D** object. ...
- 5. **GAS FLOW IN THREE-DIMENSIONAL PRINTING**
WO2018128695A2 • VELO3D INC [US]
Earliest priority: 2016-11-07 • Earliest publication: 2018-05-10
The present disclosure provides **three-dimensional (3D)** printing processes, apparatuses, software, and systems for controlling and/or treating gas borne debris in an atmosphere of a **3D printer**.
- 6. **PREHEAT THREE-DIMENSIONAL (3D) PRINTER BUILD MATERIAL**
WO2018194623A1 • HEWLETT PACKARD DEVELOPMENT CO [US]
Earliest priority: 2017-04-20 • Earliest publication: 2018-10-25
In some examples, preheat **three-dimensional (3D) printer** build material can include a heating plate of a **3D printer** to... the **3D printer**, and a heater-spreader carriage of the **3D printer** to preheat the build material from above the ...



ta any "printer*" AND (ta any "3D" OR ta all "three dimensional") AND pd >= "2017"



My Espacenet

Help

Classification search

Results



Advanced search



Filters



Tooltips

Feedback

patenttranslate

powered by EPO and Google

- Albanian
- Bulgarian
- Chinese
- Croatian
- Czech

Patent Translate



Home > Results > WO2018194652A1

Filters: Countries (publication): WO OR JP OR EP X Applicants: HEWLETT PACKARD DEVELOPMENT CO OR HEWLETT-PACKARD DEV COMPANY L P OR XEROX CORP X

90 results found, 97 publications

List view Text only

List content All

Sort by Ranking

☆ WO2018194652A1 THREE-DIMENSIONAL PRINTER

Bibliographic data

Description

Claims

Drawings

Original document

Citations

Legal status

Patent family

1. THREE-DIMENSIONAL PRINTER
 WO2018194652A1 • HEWLETT PACKARD DEVELOPMENT C...
Earliest priority: 2017-04-21 • Earliest publication: 2018-10-25
 A three-dimensional (3D) printer includes a selective solidification module to selectively solidify portions of successive layers of a build material on a build platform. The 3D printer also includes a cartridge receiver to hold a

2. THREE-DIMENSIONAL (3D) PRINTER MODULES
 WO2018194624A1 • HEWLETT PACKARD DEVELOPMENT C...
Earliest priority: 2017-04-20 • Earliest publication: 2018-10-25
 In some examples, a service module of a three-dimensional (3D) printer can include a housing, a web to clean a print head of the 3D printer, where the web is housed by the housing, and where the service module is removably

3. THREE-DIMENSIONAL (3D) PRINTING
 WO2017188967A1 • HEWLETT-PACKARD DEV COMPANY L...
Earliest priority: 2016-04-29 • Earliest publication: 2017-11-02
 In an example implementation, a method of operating a three-dimensional (3D) printing system includes forming a fused 3D object in the printing tray

Register ↗

Inventors: ENGLISH KRIS M [US], OTIS DAVID [US], ROMAN JUSTIN M [US], SCHALK WESLEY R [US], SWIER KEVIN E [US]
Applicants: HEWLETT PACKARD DEVELOPMENT CO [US]

Classification:
 IPC: **B29C64/153; B29C64/321; B33Y40/00**
 CPC: default: **B29C64/153; B29C64/321; B33Y40/00**

Application number: US2017028829W **Global Dossier** ↗

Priority numbers: US2017028829 20170421

Publication date: 2018-10-25
Filing date: 2017-04-21

Previous Next

WO 2018/194652

PCF/L/2017/028829

1/7



Filters: Countries (publication): WO OR JP OR EP X Applicants: HEWLETT PACKARD DEVELOPMENT CO OR HEWLETT-PACKARD DEV COMPANY L P OR XEROX CORP X

90 results found, 97 publications

List view List content Sort by Text only All Ranking

1. THREE-DIMENSIONAL PRINTER WO2018194652A1 • HEWLETT PACKARD DEVELOPMENT C... Earliest priority: 2017-04-21 • Earliest publication: 2018-10-25

A three-dimensional (3D) printer includes a selective solidification module to selectively solidify portions of successive layers of a build material on a build platform. The 3D printer also includes a cartridge receiver to hold a

2. THREE-DIMENSIONAL (3D) PRINTER MODULES WO2018194624A1 • HEWLETT PACKARD DEVELOPMENT C... Earliest priority: 2017-04-20 • Earliest publication: 2018-10-25

In some examples, a service module of a three-dimensional (3D) printer can include a housing, a web to clean a print head of the 3D printer, where the web is housed by the housing, and where the service module is removably

3. THREE-DIMENSIONAL (3D) PRINTING WO2017188967A1 • HEWLETT-PACKARD DEV COMPANY L... Earliest priority: 2016-04-29 • Earliest publication: 2017-11-02

In an example implementation, a method of operating a three-dimensional (3D) printing system includes forming a fused 3D object in the printing tray of a 3D printer and vibrating the tray to separate unfused material from the

4. PREHEAT THREE-DIMENSIONAL (3D) PRINTER BUILD... WO2018194623A1 • HEWLETT PACKARD DEVELOPMENT C... Earliest priority: 2017-04-20 • Earliest publication: 2018-10-25

WO2018194652A1 THREE-DIMENSIONAL PRINTER

Patent Translate

Bibliographic data Description Claims Drawings Original document Citations Legal status Patent family

[0001] THREE-DIMENSIONAL PRINTER [0002] BACKGROUND [0003] [0001] Three-dimensional (3D) printing may produce a 3D object. In particular, a 3D printer may add successive layers of material under computer control to produce the 3D object. [0004] DESCRIPTION OF THE DRAWINGS [0005] [0002] Certain examples are described in the following detailed description and in reference to the drawings, in which: [0006] [0003] Fig. 1 is a block diagram of a 3D printer in accordance with examples of the present techniques; [0007] [0004] Fig. 2 is a block diagram of a 3D printer in accordance with examples of the present techniques; [0008] [0005] Fig. 3 is a block diagram of a 3D printer in accordance with examples of the present techniques;

Previous Next WO 2018/194652 PCT/US2017/02829 1/7



Filters: Countries (publication): WO OR JP OR EP X Applicants: HEWLETT PACKARD DEVELOPMENT CO OR HEWLETT-PACKARD DEV COMPANY L P OR XEROX CORP X

90 results found, 97 publications

List view Text only List content All Sort by Ranking

- 1. THREE-DIMENSIONAL PRINTER WO2018194652A1 • HEWLETT PACKARD DEVELOPMENT C... Earliest priority: 2017-04-21 • Earliest publication: 2018-10-25 A three-dimensional (3D) printer includes a selective solidification module to selectively solidify portions of successive layers of a build material on a build platform. The 3D printer also includes a cartridge receiver to hold a...
2. THREE-DIMENSIONAL (3D) PRINTER MODULES WO2018194624A1 • HEWLETT PACKARD DEVELOPMENT C... Earliest priority: 2017-04-20 • Earliest publication: 2018-10-25 In some examples, a service module of a three-dimensional (3D) printer can include a housing, a web to clean a print head of the 3D printer, where the web is housed by the housing, and where the service module is removably...
3. THREE-DIMENSIONAL (3D) PRINTING WO2017188967A1 • HEWLETT-PACKARD DEV COMPANY L... Earliest priority: 2016-04-29 • Earliest publication: 2017-11-02 In an example implementation, a method of operating a three-dimensional (3D) printing system includes forming a fused 3D object in the printing tray of a 3D printer and vibrating the tray to separate unfused material from the...
4. PREHEAT THREE-DIMENSIONAL (3D) PRINTER BUILD... WO2018194623A1 • HEWLETT PACKARD DEVELOPMENT C... Earliest priority: 2017-04-20 • Earliest publication: 2018-10-25

WO2018194652A1 THREE-DIMENSIONAL PRINTER

Patent Translate

Bibliographic data Description Claims Drawings Original document Citations Legal status Patent family

Original claims Claims tree

1. CLAIMS

What is claimed is:

1. A three-dimensional (3D) printer comprising: a selective solidification module to selectively solidify portions of successive layers of a build material on a build platform; and a cartridge receiver to hold a removable material cartridge to accept material into the removable material cartridge from the 3D printer and to make available material from the removable material cartridge for the 3D printer to print the 3D object.

The 3D printer of claim 1, comprising a removable build unit comprising a build enclosure and the build platform, wherein the removable material cartridge comprises an enclosure to contain the material, wherein the cartridge receiver comprises a cavity, receptacle, slot, or sleeve, or any

Previous Next WO 2018/194652 PCT/US2017/02829 1/7 3D Printer 102 Selective Solidification Module 104 Receiver 106



Filters: Countries (publication): WO OR JP OR EP X Applicants: HEWLETT PACKARD DEVELOPMENT CO OR HEWLETT-PACKARD DEV COMPANY L P OR XEROX CORP X

90 results found, 97 publications

List view Text only List content All Sort by Ranking

1. THREE-DIMENSIONAL PRINTER WO2018194652A1 • HEWLETT PACKARD DEVELOPMENT C... Earliest priority: 2017-04-21 • Earliest publication: 2018-10-25

A three-dimensional (3D) printer includes a selective solidification module to selectively solidify portions of successive layers of a build material on a build platform. The 3D printer also includes a cartridge receiver to hold a

2. THREE-DIMENSIONAL (3D) PRINTER MODULES WO2018194624A1 • HEWLETT PACKARD DEVELOPMENT C... Earliest priority: 2017-04-20 • Earliest publication: 2018-10-25

In some examples, a service module of a three-dimensional (3D) printer can include a housing, a web to clean a print head of the 3D printer, where the web is housed by the housing, and where the service module is removably

3. THREE-DIMENSIONAL (3D) PRINTING WO2017188967A1 • HEWLETT-PACKARD DEV COMPANY L... Earliest priority: 2016-04-29 • Earliest publication: 2017-11-02

In an example implementation, a method of operating a three-dimensional (3D) printing system includes forming a fused 3D object in the printing tray of a 3D printer and vibrating the tray to separate unfused material from the

4. PREHEAT THREE-DIMENSIONAL (3D) PRINTER BUILD... WO2018194623A1 • HEWLETT PACKARD DEVELOPMENT C... Earliest priority: 2017-04-20 • Earliest publication: 2018-10-25

☆ WO2018194652A1 THREE-DIMENSIONAL PRINTER Patent Translate

Bibliographic data Description Claims Drawings Original document Citations Legal status Patent family

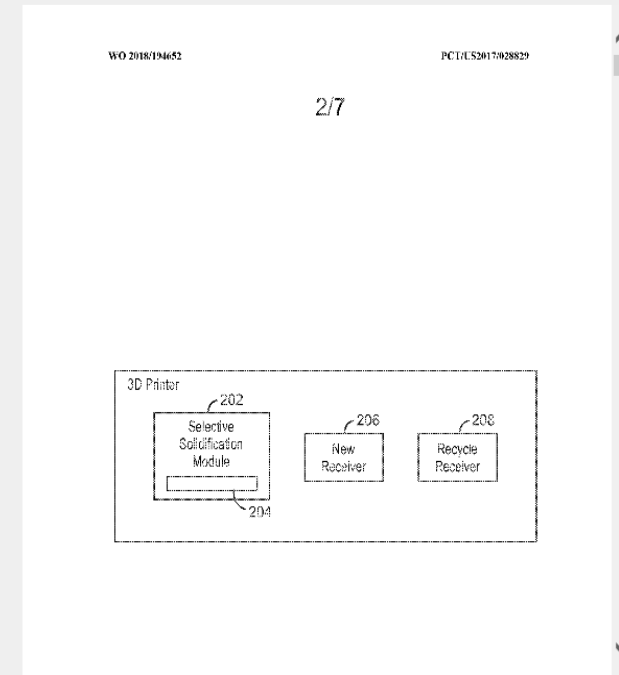
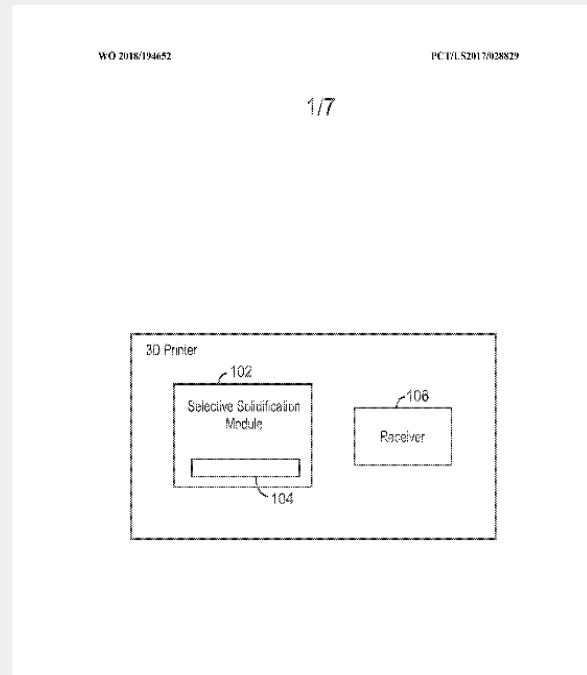



Filters: Countries (publication): WO OR JP OR EP X Applicants: HEWLETT PACKARD DEVELOPMENT CO OR HEWLETT-PACKARD DEV COMPANY L P OR XEROX CORP X

90 results found, 97 publications

List view List content Sort by Text only All Ranking

- 1. THREE-DIMENSIONAL PRINTER WO2018194652A1 • HEWLETT PACKARD DEVELOPMENT C... Earliest priority: 2017-04-21 • Earliest publication: 2018-10-25 A three-dimensional (3D) printer includes a selective solidification module to selectively solidify portions of successive layers of a build material on a build platform. The 3D printer also includes a cartridge receiver to hold a
2. THREE-DIMENSIONAL (3D) PRINTER MODULES WO2018194624A1 • HEWLETT PACKARD DEVELOPMENT C... Earliest priority: 2017-04-20 • Earliest publication: 2018-10-25 In some examples, a service module of a three-dimensional (3D) printer can include a housing, a web to clean a print head of the 3D printer, where the web is housed by the housing, and where the service module is removably
3. THREE-DIMENSIONAL (3D) PRINTING WO2017188967A1 • HEWLETT-PACKARD DEV COMPANY L... Earliest priority: 2016-04-29 • Earliest publication: 2017-11-02 In an example implementation, a method of operating a three-dimensional (3D) printing system includes forming a fused 3D object in the printing tray of a 3D printer and vibrating the tray to separate unfused material from the
4. PREHEAT THREE-DIMENSIONAL (3D) PRINTER BUILD... WO2018194623A1 • HEWLETT PACKARD DEVELOPMENT C... Earliest priority: 2017-04-20 • Earliest publication: 2018-10-25

☆ WO2018194652A1 THREE-DIMENSIONAL PRINTER

Patent Translate

Bibliographic data Description Claims Drawings Original document Citations Legal status Patent family

Page 1 /23 Previous Next

Bibliographic data Description Claims Drawings Search report

(12) INTERNATIONAL APPLICATION PUBLISHED UNDER THE PATENT COOPERATION TREATY (PCT)

(19) World Intellectual Property Organization International Bureau



(43) International Publication Date 25 October 2018 (25.10.2018)

WIPO | PCT

(10) International Publication Number WO 2018/194652 A1

(51) International Patent Classification: B29C 64/153 (2017.01) B33Y 40/00 (2015.01) B29C 64/321 (2017.01)

(74) Agent: LEMMON, Marcus B. et al.; IIP Inc., 3390 East Harmony Road, Mail Stop 35, Fort Collins, Colorado 80528 (US).

(21) International Application Number: PCT/US2017/028829

(81) Designated States (unless otherwise indicated, for every kind of national protection available): AE, AG, AL, AM, AO, AT, AU, AZ, BA, BB, BG, BH, BN, BR, BW, BY, BZ, CA, CH, CL, CN, CO, CR, CU, CZ, DE, DI, DK, DM, DO,

(22) International Filing Date:



Filters: Countries (publication): WO OR JP OR EP X Applicants: HEWLETT PACKARD DEVELOPMENT CO OR HEWLETT-PACKARD DEV COMPANY L P OR XEROX CORP X

90 results found, 97 publications

List view Text only List content All Sort by Ranking

- 1. THREE-DIMENSIONAL PRINTER WO2018194652A1 • HEWLETT PACKARD DEVELOPMENT C... Earliest priority: 2017-04-21 • Earliest publication: 2018-10-25 A three-dimensional (3D) printer includes a selective solidification module to selectively solidify portions of successive layers of a build material on a build platform. The 3D printer also includes a cartridge receiver to hold a
2. THREE-DIMENSIONAL (3D) PRINTER MODULES WO2018194624A1 • HEWLETT PACKARD DEVELOPMENT C... Earliest priority: 2017-04-20 • Earliest publication: 2018-10-25 In some examples, a service module of a three-dimensional (3D) printer can include a housing, a web to clean a print head of the 3D printer, where the web is housed by the housing, and where the service module is removably
3. THREE-DIMENSIONAL (3D) PRINTING WO2017188967A1 • HEWLETT-PACKARD DEV COMPANY L... Earliest priority: 2016-04-29 • Earliest publication: 2017-11-02 In an example implementation, a method of operating a three-dimensional (3D) printing system includes forming a fused 3D object in the printing tray of a 3D printer and vibrating the tray to separate unfused material from the
4. PREHEAT THREE-DIMENSIONAL (3D) PRINTER BUILD... WO2018194623A1 • HEWLETT PACKARD DEVELOPMENT C... Earliest priority: 2017-04-20 • Earliest publication: 2018-10-25

WO2018194652A1 THREE-DIMENSIONAL PRINTER Patent Translate
Bibliographic data Description Claims Drawings Original document Citations Legal status Patent family
Page 23 /23 Previous Next
Bibliographic data Description Claims Drawings Search report
INTERNATIONAL SEARCH REPORT
International application No. PCT/US 2017/028829
A. CLASSIFICATION OF SUBJECT MATTER B29C 64/153 (2017.01) B29C 64/321 (2017.01) B33Y 40/00 (2015.01)
According to International Patent Classification (IPC) or to both national classification and IPC
B. FIELDS SEARCHED
Minimum documentation searched (classification system followed by classification symbols) B05D 3/06, B22F 3/105, 3/16, 8/00, B29C 64/153, 64/321, B33Y 40/00, B41J 2/18
Documentation searched other than minimum documentation to the extent that such documents are included in the fields searched



Espacenet
Patent search

ta any "printer" AND (ta any "3D" OR ta all "three dimensional") AND pd >= "2017"



Office/Language

My Espacenet

Help

Classification search

Results

Advanced search

Filters

Tooltips

Feedback

Home > Results > EP3364641A1

Filters: Countries (publication): WO OR JP OR EP X Applicants: HEWLETT PACKARD DEVELOPMENT CO OR HEWLETT-PACKARD DEV COMPANY L P OR XEROX CORP X

90 results found, 97 publications

List view Text only List content All Sort by Ranking

66. ELECTROSTATIC 3-D PRINTER USING LEVELING MAT... EP3255504A1 • XEROX CORP [US] Earliest priority: 2016-06-07 • Earliest publication: 2017-12-07 A three-dimensional (3-D) printer includes build and support material development stations (114, 116) positioned to transfer layers of

67. ELECTROSTATIC 3-D PRINTER USING LAYER AND M... EP3255505A1 • XEROX CORP [US] Earliest priority: 2016-06-07 • Earliest publication: 2017-12-07 A three-dimensional (3-D) printer includes build and support material development stations (114, 116) positioned to transfer layers of

68. SYSTEM AND METHOD FOR DECREASING TIME FOR... EP3364641A1 • XEROX CORP [US] Earliest priority: 2017-02-16 • Earliest publication: 2018-08-16 A three-dimensional object printer has a controller that operates pluralities of ejectors ejecting drops of different materials having different

☆ EP3364641A1 SYSTEM AND METHOD FOR DECREASING TIME FOR PRINTING LAYERS IN THREE-DIMENSIONAL OBJECTS AND FOR ENHANCING COLOR FIDELITY AT THE SURFACE OF THREE-DIMENSIONAL OBJECTS

Also published as

Bibliographic data Description Claims Drawings Original document Citations Legal status Patent family

Cited documents < EP3364641A1 < Citing documents

Publication ^	Priority date ^	Publication date ^	Applicants ^	Title ^	IPC ^
XP055366828				ALAN BRUNTON ET AL: "Pushing the Limits of 3D Color Printing", ACM TRANSACTIONS ON GRAPHICS (TOG), vol. 35, no. 1, 1 December 2015 (2015-12-01), US, pages 1 - 13, XP055366828, ISSN: 0730-0301, DOI: 10.1145/2832905	
US10065376B2	2014-05-22	2017-05-18	MIMAKI	THREE-DIMENSIONAL	B29C67/00,



Espacenet Patent search

ta any "printer" AND (ta any "3D" OR ta all "three dimensional") AND pd >= "2017"



Office/Language

My Espacenet Help Classification search Results Advanced search Filters Tooltips

Feedback

Home > Results > EP3364641A1

Filters: Countries (publication): WO OR JP OR EP X Applicants: HEWLETT PACKARD DEVELOPMENT CO OR HEWLETT-PACKARD DEV COMPANY L P OR XEROX CORP X

90 results found, 97 publications

List view Text only List content All Sort by Ranking

☆ EP3364641A1 SYSTEM AND METHOD FOR DECREASING TIME FOR PRINTING LAYERS IN THREE-DIMENSIONAL OBJECTS AND FOR ENHANCING COLOR FIDELITY AT THE SURFACE OF THREE-DIMENSIONAL OBJECTS

Also published as

Bibliographic data Description Claims Drawings Original document Citations Legal status Patent family

66. ELECTROSTATIC 3-D PRINTER USING LEVELING MAT... EP3255504A1 • XEROX CORP [US]

Earliest priority: 2016-06-07 • Earliest publication: 2017-12-07

A three-dimensional (3-D) printer includes build and support material development stations (114, 116) positioned to transfer layers of

67. ELECTROSTATIC 3-D PRINTER USING LAYER AND M... EP3255505A1 • XEROX CORP [US]

Earliest priority: 2016-06-07 • Earliest publication: 2017-12-07

A three-dimensional (3-D) printer includes build and support material development stations (114, 116) positioned to transfer layers of

68. SYSTEM AND METHOD FOR DECREASING TIME FOR... EP3364641A1 • XEROX CORP [US]

Earliest priority: 2017-02-16 • Earliest publication: 2018-08-16

A three-dimensional object printer has a controller that operates pluralities of ejectors ejecting drops of different materials having different

Event indicator	Category	Event Description	Countries	Event date	Effective date	Details
EP AK	W: Other	DESIGNATED CONTRACTING STATES:	AL AT BE BG CH CY CZ DE DK EE ES FI FR GB GR HR HU IE IS IT LI LT LU LV MC MK MT NL NO PL PT RO RS SE SI SK SM TR	2018-08-22		
EP AV	W: Other	REQUEST FOR VALIDATION OF	MA MD TN	2018-08-22		



Espacenet Patent search

ta any "printer" AND (ta any "3D" OR ta all "three dimensional") AND pd >= "2017"



Office/Language

My Espacenet Help Classification search Results Advanced search Filters Tooltips

Feedback

Home > Results > EP3364641A1

Filters: Countries (publication): WO OR JP OR EP Applicants: HEWLETT PACKARD DEVELOPMENT CO OR HEWLETT-PACKARD DEV COMPANY L P OR XEROX CORP

90 results found, 97 publications

List view Text only List content All Sort by Ranking

66. ELECTROSTATIC 3-D PRINTER USING LEVELING MAT... EP3255504A1 • XEROX CORP [US] Earliest priority: 2016-06-07 • Earliest publication: 2017-12-07

67. ELECTROSTATIC 3-D PRINTER USING LAYER AND M... EP3255505A1 • XEROX CORP [US] Earliest priority: 2016-06-07 • Earliest publication: 2017-12-07

68. SYSTEM AND METHOD FOR DECREASING TIME FOR... EP3364641A1 • XEROX CORP [US] Earliest priority: 2017-02-16 • Earliest publication: 2018-08-16

☆ EP3364641A1 SYSTEM AND METHOD FOR DECREASING TIME FOR PRINTING LAYERS IN THREE-DIMENSIONAL OBJECTS AND FOR ENHANCING COLOR FIDELITY AT THE SURFACE OF THREE-DIMENSIONAL OBJECTS

Also published as

Bibliographic data Description Claims Drawings Original document Citations Legal status Patent family

Simple family INPADOC family

CCD

Table with 4 columns: Publication, Title, Publication date, Applicants. Rows include KR20180094780A, CN108437443A, and EP3364641A1.



Home > Results > EP3364641A1

Filters: Countries (publication): WO OR JP OR EP X Applicants: HEWLETT PACKARD DEVELOPMENT CO OR HEWLETT-PACKARD DEV COMPANY L P OR XEROX CORP X

90 results found, 97 publications

List view Text only List content All Sort by Ranking

66. ELECTROSTATIC 3-D PRINTER USING LEVELING MAT... EP3255504A1 • XEROX CORP [US] Earliest priority: 2016-06-07 • Earliest publication: 2017-12-07 A three-dimensional (3-D) printer includes build and support material development stations (114, 116) positioned to transfer layers of

67. ELECTROSTATIC 3-D PRINTER USING LAYER AND M... EP3255505A1 • XEROX CORP [US] Earliest priority: 2016-06-07 • Earliest publication: 2017-12-07 A three-dimensional (3-D) printer includes build and support material development stations (114, 116) positioned to transfer layers of

68. SYSTEM AND METHOD FOR DECREASING TIME FOR... EP3364641A1 • XEROX CORP [US] Earliest priority: 2017-02-16 • Earliest publication: 2018-08-16 A three-dimensional object printer has a controller that operates pluralities of ejectors ejecting drops of different materials having different

69. MATERIAL FEEDER FOR ENGINEERING POLYMER EJ... JP2017105176A • XEROX CORP Earliest priority: 2015-12-08 • Earliest publication: 2017-06-08

☆ EP3364641A1 SYSTEM AND METHOD FOR DECREASING TIME FOR PRINTING LAYERS IN THREE-DIMENSIONAL OBJECTS AND FOR ENHANCING COLOR FIDELITY AT THE SURFACE OF THREE-DIMENSIONAL OBJECTS

Also published as Bibliographic data Description Claims Drawings Original document Citations Legal status Patent family

Register

Inventors: MANTELL DAVID A [US], SCHWEID STUART A [US] Applicants: XEROX CORP [US]

Classification: IPC: B29C64/393; B33Y50/02; H04N1/60 CPC: default: B29C64/393; B33Y50/02; H04N1/60; B29C64/112; B29C64/386; B33Y10/00; B33Y30/00; B29K2105/0058; B29K2995/002

Application number: EP18153534A Global Dossier

Priority numbers: US201715434689 20170216

Publication date: 2018-08-22 Filing date: 2018-01-25 Priority date: 2017-02-16

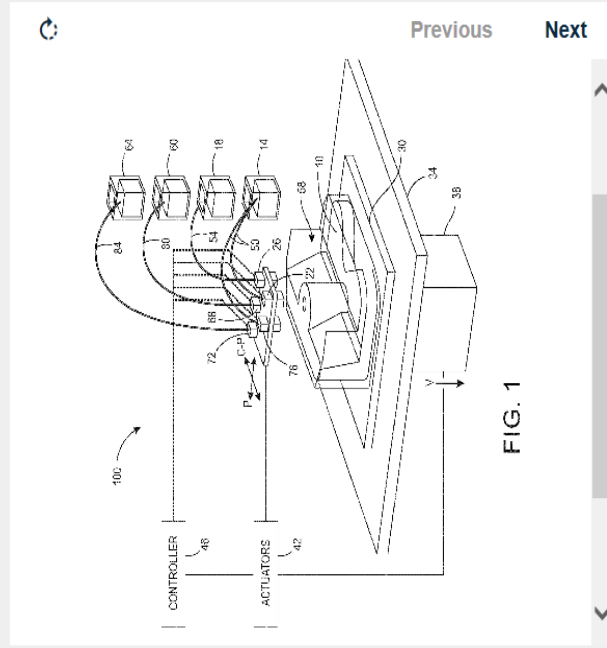



EP3364641
European procedure
About this file
Legal status
Federated register
Event history
Citations
Patent family
All documents

Quick help

- [What happens if I click on the "XML" or "ST36" buttons?](#)
- [What kind of information can be found if I click on the "Show history" button?](#)
- [What kind of information can be found under "Status"?](#)
- [What do the digits in square brackets refer to?](#)
- [What does N/P stand for?](#)
- [What does the letter in square brackets stand for in the "Documents cited" part?](#)
- [Is it possible to navigate in the result list?](#)
- [What kind of information can be found under "Lapses during opposition"?](#)
- [What are validation states?](#)
- [What are extension states?](#)

About this file: EP3364641

Refine search ↓ ST36 ↗ Espacenet Submit observations Report error Print

EP3364641 - SYSTEM AND METHOD FOR DECREASING TIME FOR PRINTING LAYERS IN THREE-DIMENSIONAL OBJECTS AND FOR ENHANCING COLOR FIDELITY AT THE SURFACE OF THREE-DIMENSIONAL OBJECTS [\[Right-click to bookmark this link\]](#)

Status The application has been published
Status updated on 20.07.2018
Database last updated on 26.11.2018

Most recent event 20.07.2018 Publication in section I.1 EP Bulletin published on 22.08.2018 ↗ [\[2018/34\]](#)

Applicant(s) For all designated states
Xerox Corporation
Mailstop: XRX2-020
100 Clinton Avenue South
Rochester, NY 14644 / US

[2018/34]

Inventor(s) 01 / MANTELL, David A.
275 Yarmouth Road
Rochester, NY New York 14610 / US

02 / SCHWEID, Stuart A.
20 Knobb Hill Drive
Pittsford, NY New York 14534 / US

↗ [\[2018/34\]](#)

Representative(s) Gill Jennings & Every LLP
The Broadgate Tower
20 Primrose Street

Děkuji Vám za pozornost.



Úřad průmyslového vlastnictví

Antonína Čermáka 2a,
160 68 Praha 6-Bubeneč

Použité zdroje:

EPOPIC 12.-14.11.2018,

dostupné z: <https://www.epo.org/learning-events/events/conferences/pi-conference/programme.html>